



Model ASL

High Accuracy Low Differential Pressure Transducer

Features

- 0.25% typical total error band
- Reduce calibration time
- High accuracy: $\pm 0.07\%$ FS
- End point method linearity
- High overpressure capability: $> 100X$ range
- Low thermal error
- Excellent stability: $< 0.15\%$ FS/YR
- Calibrate using SecureCal™ calibration key
- High line pressure capability
- Unidirectional & bidirectional models

Applications

- Filter pressure
- Leak detection systems
- Exhaust pressure
- Medical instrumentation
- Part integrity testing
- Test stands
- Wind tunnels
- Industrial high accuracy

Setra's Model ASL is the highest accuracy transducer for measuring low differential pressure in the AccuSense™ product line. Its $\pm 0.07\%$ FS accuracy is calibrated using the "End Point Method" which improves linearity when compared to competitive transducers, which use the "Best Fit Straight Line Method" of calibration. The ASL's calibration is tamper proof by utilizing a SecureCal™ calibration key which eliminates inadvertent adjustments, while allowing authorized users to adjust the sensor's calibration coefficients for a true sensor calibration. The design of the ASL offers class leading overpressure capability and multiple pressure and electrical fittings to accommodate a wide range of applications.

High accuracy for demanding applications

The Model ASL differential pressure transducer uses a resonant variable capacitance sensor. This sensor is linearized and thermally compensated through a computerized curve fitting algorithm that optimizes the sensor's linearity for maximum accuracy in demanding applications.

Robust design & construction for reliable service

The Model ASL is designed and built to withstand demanding applications. The laser welded sensor construction, designed with positive and negative overpressure stops, enables the sensor to resist overpressure conditions up to $100X$ in all pressure ranges.

Fast & secure calibration

The Model ASL is ideal for the Test & Measurement industry because it adheres to the stringent accuracy requirements. In order to make adjustments, the ASL utilizes the SecureCal™ calibration key, providing secure calibration. The SecureCal™ provides the ability to calibrate zero and span coefficients through a simple push button and rotary adjustment dial. The SecureCal™ also offers the option to restore factory defaults for fail-safe sensor calibration.



Specifications

Performance Data

Internal volumes	Positive Port 0.03 cu. in. Reference Port 0.75 cu. in.
Operable line pressure	Vacuum to 250 PSI max
Maximum volume change at FS	0.002 cu. in.
Long-term stability	<0.15% FS/Year, Typical
Response time to pressure input (From 100% to 10% of pressure range)	<10 ms for Voltage Output <50 ms for Current Output
Line pressure effect	2% FS/100 PSIG
Zero offset positive effect	<0.1%/G
Unit factory calibrated in vertical position (pressure port download)	

Physical Description

Electrical terminations	6-Conductor Cable, Pigtail 6-Pin Bayonet Connector
Dimensions	See reverse side
Weight	13 oz. (360 g)
Moisture/splash resistance	NEMA 4X (IP65)
Pressure fittings	See ordering information
Case materials	Stainless steel

Pressure Media

Clean, dry gases compatible with 300 series stainless steel and 17-4 pH stainless steel.

Approvals

CE, RoHS

¹RSS: Root Sum Square of endpoint linearity, Hysteresis and Non-repeatability at constant temperature.

²Current consumption: ≥70mA of inrush current for approximately 5ms.

US Patent # 6,789,429

Specifications subject to change without notice.

Overpressure Capability

Pressure Ranges	Burst Pressure ¹	Standard Proof Pressure Option Code "00" ²	High Proof Pressure Option Code "01" ²
0 to 1" WC	175 PSI, 12 Bar	±8 PSI	±25 PSI
0 to 2.5" WC, 5 mBar	200 PSI, 15 Bar	±10 PSI, ±700 mBar	±75 PSI, ±5 Bar
0 to 5" WC, 10 mBar	300 PSI, 20 Bar	±20 PSI, ±1 Bar	±100 PSI, ±7 Bar
0 to 10" WC, 25 mBar	300 PSI, 20 Bar	±30 PSI, ±2 Bar	±150 PSI, ±10 Bar
0 to 30" WC, 1 PSI, 100 mBar	300 PSI, 20 Bar	±50 PSI, ±4 Bar	±150 PSI, ±10 Bar

¹Burst Pressure: The maximum pressure that may be applied to the positive pressure port without rupturing the diaphragm or reference pressure containment.

²Proof Pressure: The maximum recoverable pressure that may be applied without charging performance beyond specification: ±0.5% Zero Shift, Typical.

Environmental Data

Temperature calibrated °F (°C)	-4 to +140 (-20 to +60)
Operating temperature ¹ °F (°C)	-40 to +124 (-40 to +85)
Storage temperature °F (°C)	-40 to +185 (-40 to +85)
Higher or lower limits available (consult factory)	

Electrical Data

Excitation range	9 to 30VDC (5VDC & 4-20 mA output) 15 to 30VDC (10 VDC output)
Current consumption ²	<23 mA
Miswiring	Reverse Excitation Protection
Warm-up, Environmental	Within ±0.02% FS after 15 min warm-up time
Signal output ranges	0 to 5 VDC, 0 to 10 VDC (4-wire), 4-20mA (2-wire)

Accuracy data

	Accuracy code "A"	Accuracy code "C"
Accuracy	< ±0.07% FS RSS	≤ ±0.1% FS RSS
Non-linearity, End-point (typ.)	< ±0.03% FS	≤ ±0.08% FS
Hysteresis (typ.)	< 0.03% FS	≤ ±0.06% FS
Non-repeatability (typ.)	< ±0.02% FS	≤ ±0.04% FS
Span setting tol.	< ±0.1% FS	< ±0.15% FS
Zero offset tol. (typ.)	< ±0.1% FS	< ±0.20% FS
Thermal total error band (-20°C to 60°C)	< ±0.25% FS < ±0.5% FS Max.	< ±0.5% < ±1% Max.

Ordering information

Example part number: ASL1001WB1F2B03A00;

ASL Transducer, ±1" W.C. Pressure Range, 1/8" NPT Female Reference Port, 0 to 5 VDC Output, 3 Foot Cable, <±0.07% FS RSS Accuracy, No Options:

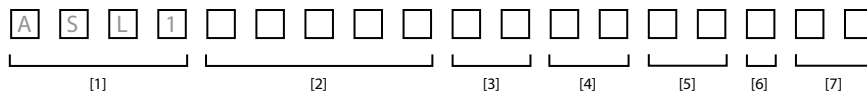

[1]	[2] or [2]	[3]	[4]	[5]	[6]	[7]	
Model	Pressure range ¹ (unidirectional)	Pressure range ¹ (bidirectional)	Process/reference port	Output	Elec. termination	Accuracy	Option
ASL1 Model ASL	R25WD ² 0 to 0.25" WC	0R1WB ² ±0.1" WC	1F 1/8" NPT Int./ Barb	2B 0 to 5 VDC	03 3 ft./1 m std. cable	A <±0.07% FS RSS	00 None, standard
	0R5WD 0 to 0.5" WC	R25WB ±0.25" WC	FF 1/8 NPT Int./ 1/8 NPT Int.	2C 0 to 10 VDC	B3 Std. 6-pin ext. bayonet connect, std. wiring	C <±0.1% FS RSS	01 High overpressure
	001WD 0 to 1" WC	0R5WB ±0.5" WC	1M 1/8" NPT Ext./ Barb	11 4 to 20 mA			
	002WD 0 to 2" WC	001WB ±1" WC	J7 7/16-20 SAE Ext./Barb				
	2R5WD 0 to 2.5" WC	002WB ±2" WC					
	005WD 0 to 5" WC	005WB ±5" WC					
	010WD 0 to 10" WC	015WB ±15" WC					
	030WD 0 to 30" WC	005MB ±5 mBar					
	040WD 0 to 40" WC	010MB ±10 mBar					
	005MD 0 to 5 mBar	025MB ±25 mBar					
	010MD 0 to 10 mBar	050MB ±50 mBar					
	025MD 0 to 25 mBar	001PB ±1 PSID					
	050MD 0 to 50 mBar	002PB ±2 PSID					
	100MD 0 to 100 mBar	025LB ² ±30 Pa					
	001PD 0 to 1 PSID	050LB ±60 Pa					
	001PD 0 to 2 PSID	125LB ±125 Pa					
	050LD ² 0 to 50 Pa						
	100LD 0 to 100 Pa						
	250LD 0 to 250 Pa						

Accessories

- (a) See data sheet for more information on Setra's SecureCal™ calibration key.
- (b) 6-pin bayonet connector assembly with strain relief. Order separately: Part No. 600751

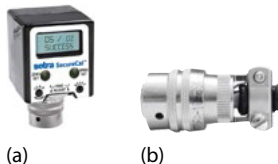

¹ Other ranges and engineering units are available (e.g. Pa, kPa).
² Range only available with accuracy code "C".

Dimensions

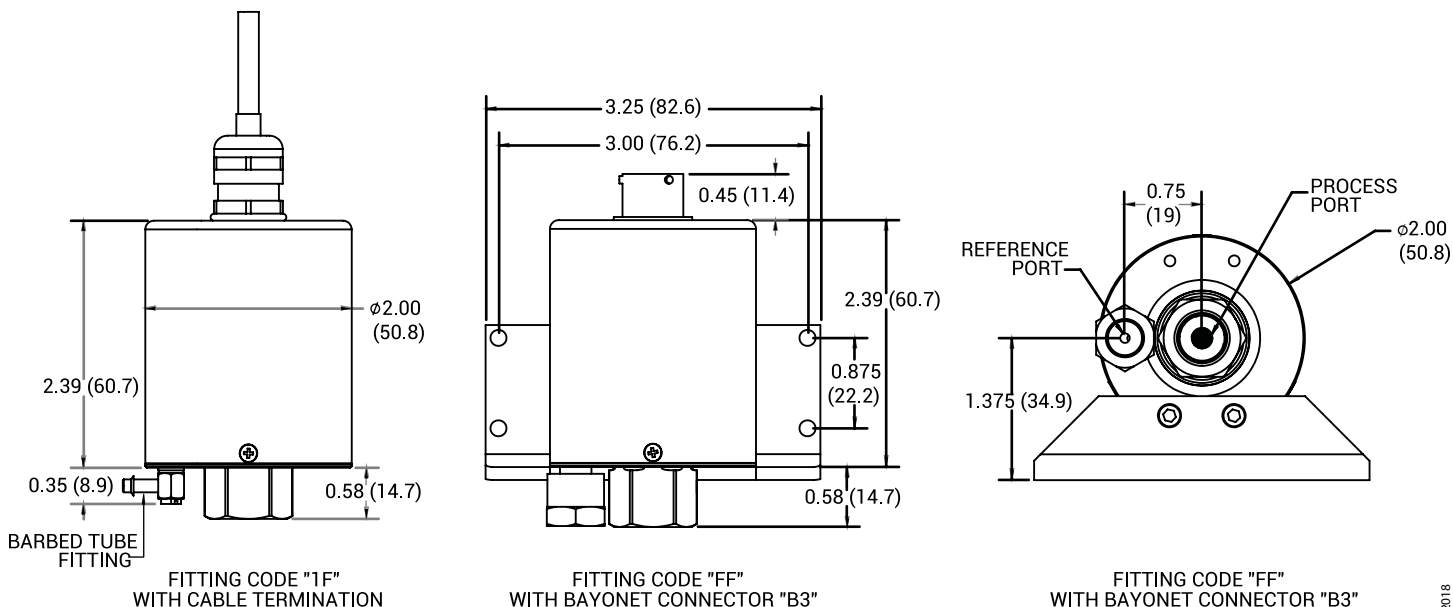

inches (mm)